

WIRING IDEA OF 193BI2

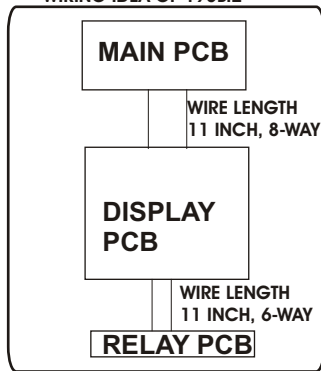

ACCESSORIES SUPPLIED WITH THIS AREAS FOLLOWS

- 1 - 27 MM BUZZER, MODEL B27 WITH 2-WAY RMC.
- 2 - TRANSFORMER PLATE WITH TRANSFORMER FITTED ON IT.
- 3 - DISPLAY PCB: 193BI1DB 150704
- 4 - MAIN PCB: 193BT1MB
- 5 - RELAY & SSR PCB: 193BTRLY
- 6 - USER GUIDE.
- 7 - CONNECTION DIAGRAM.
- 8 - CONNECTION DETAILS IN BRIEF
- 9 - TEST & CALIBRATION CERTIFICATE.
- 10 - ELECTRICALS NOISE FILTER CARD FITTED ON TRANSFORMER PLATE.

Trouble Shooting :

- 1) Sensor open indication : Display shows "Err".
- 2) Sensor reverse : If the RTD is not connected according to connection diagram. Then it will show erratic temperature
- 3) Not showing proper temp. : Loose connection on terminal or calibration problem.
- 4) Problem in relay operation - Check connections as per wiring diagram given BELOW,

**MODEL: 193BI4
BABY INCUBATOR CONTROLLER**

Features

- 1) SET POINT ADJUSTMENT ON FRONT WITH SOFT KEYS.
- 2) SSR OUTPUT IS GIVEN.
- 3) MASTER RELAY IS PROVIDED FOR SAFETY WITH NECESSARY LOGIC.
- 4) MANUAL / SERVO MODE INDICATION ON SEPARATE LEDS
- 5) AUDIO ALARM MUTE INDICATION ON LED
- 6) SKIN & AIR PROBE OPEN INDICATION ON LED
- 7) POWER FAIL INDICATION ON LED WITH AUDIO ALARM.
- 8) PROGRAMMABLE MUTE TIMER.
- 9) 5 Amp RELAY CONTACT FOR RESISTIVE LOAD.
- 10) APGAR TIMER IS GIVEN.

Specifications

- 1) INPUT SENSOR : Pt-100 (RTD) FOR SKIN PROBE & AIR PROBE,
- 2) SERVO / MANUAL MODE OF OPERATION (USER SELECTABLE),
- 3) SET POINT: 30.0 to 40.0 °C
- 4) MOUNTING : PANEL MOUNTING.
- 5) DUTY CYCLE : 30 SECS FIXED.
- 6) POWER CONSUMPTION : 10 VA MAX.
- 7) DISPLAY : 1 INCH,3 DIGIT, 7-SEG, RED LED DISPLAY FOR SKIN & 0.5 INCH3 DIGIT, 7-SEG, GREEN LED DISPLAY FOR SET TEMPERATURE INDICATION.
2 LINE, 16-CHARACTER LCD DISPLAY FOR SET, PROCESS VALUE & FAULT INDICATION.
- 8) SUPPLY : 220 V AC +/- 15% 50 Hz
- 9) ALARM : 0.0°C to 9.9°C ABOVE & BELOW SKIN SET.
- 10) MUTE TIME: 0 TO 15 MINS (SELECTABLE).
- 11) APGAR LED WILL FLASH ON EVERY SECONDS AS THE TIME STARTS.
- 12) MUTE LED WILL FLASH ON EVERY SECONDS AS THE MUTE TIME STARTS.
- 13) POWER SETTING : 10 TO 99% FOR MANUAL MODE.
- 14) SERVO / MANUAL MODE INDICATION WITH LED.
- 15) °C/°F SELECTION ON FRONT WITH SOFT KEY, ALSO THE INDICATION FOR °F MODE IS GIVEN ON LED.
- 16) SET POINT ADJUSTMENT WITH TWO KEYS SO NO ONE CAN DISTURB IT EASILY.
- 17) MASTER RELAY WITH 5 AMP 1C/O CONTACT FOR RESISTIVE LOAD & SSR OUTPUT WITH 6AMP CONTACT.
- 18) MASTER RELAY WILL CUT-OFF AS THE SKIN TEMP GOES ABOVE 38°C OR IF AIR TEMPERATURE GOES ABOVE 39°C & SSR WILL BE OFF AS THE SKIN TEMP GOES ABOVE 37°C.
- 19) SET HIGH, SET LOW, PROBE FAIL, POWER FAIL, HIGH TEMP & LOW TEMP ALARM INDICATION ON FLAT LEDS & ON LCD DISPLAY.
- 20) "PV" DISPLAY WILL FLASH ON EVERY ERROR CONDITION.

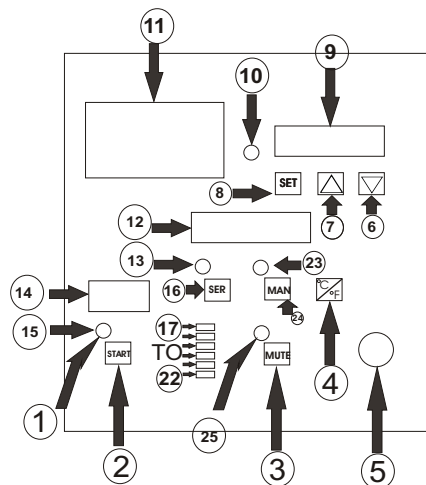

- 1:- APGAR TIMER START LED
- 2:- APGAR TIMER START KEY
- 3:- MUTE KEY
- 4:- °C / °F SELECTION KEY
- 5:- RTD CONNECTOR NOT GIVEN
- 6:- DECREMENT KEY
- 7:- INCREMENT KEY
- 8:- SET KEY
- 9:- SKIN SET / AIR TEMPERATURE (DISPLAY-2)
- 10:- °F MODE INDICATION LED
- 11:- SKIN PROCESS TEMPERATURE (DISPLAY-1)
- 12:- LCD DISPLAY
- 13:- SKIN MODE INDICATION LED
- 14:- APGAR TIMER DISPLAY
- 15:- APGAR TIMER START INDICATION LED
- 16:- SKIN MODE KEY
- 17:- HIGH TEMPERATURE ALARM LED
- 18:- LOW TEMPERATURE ALARM LED
- 19:- AIR HIGH LED
- 20:- AIR LOW LED
- 21:- POWER FAIL LED
- 22:- PROBE FAIL LED.
- 23:- AIR MODE INDICATION LED
- 24:- AIR MODE KEY
- 25:- MUTE INDICATION LED.

CONNECTION FOR LOAD

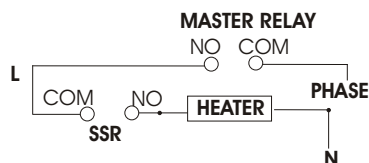

**IF MASTER RELAY FAILS THEN ,
WHOLE SYSTEM WILL SWITCH OFF**



OPERATING MANUAL OF BABY INCUBATOR.

DISPLAY-1 IS TO INDICATE SKIN PROCESS TEMPERATURE , DISPLAY-2 IS TO INDICATE SKIN SET / AIR TEMPERATURE & DISPLAY-3 IS TO INDICATE "APGAR" TIME.

DURING "POWER ON" DISPLAY WILL SHOW "rtd" ON DISPLAY-1. LCD DISPLAY WILL SHOW SKIN(SKN) PROCESS & SKIN SET TEMPERATURE IN °C.

HOW TO ADJUST SET POINT ?

PUSH SET KEY, SET DISPLAY WILL START WITH SET NUMBER & "SET" ALTERNATELY. SET IT BY UP / DOWN ARROW KEYS TO DESIRED VALUE. THIS IS SKIN TEMPERATURE SET VALUE IF THE USER IS IN SKIN MODE OR DURING "POWER ON". (MODE IS INDICATED ON THE RIGHT CORNER OF THE FIRST ROW OF LCD DISPLAY) AGAIN PUSH SET KEY TO GO OUT OF THIS MODE. IF IT IS NOT PRESSED THEN THE SET TEMPERATURE WILL BE DISPLAYED (FLASHING WITH SET NO) FOR 30 SECONDS & THEN IT WILL SHOW AIR TEMPERATURE BY SAVING NEW VALUE OF SET TEMPERATURE. NEW SET VALUE WILL NOT GEN ENTERED IN THE MEMORY UNTIL & UNLESS THE SET DISPLAY GOES OUT OF SET MODE.

IF ONE HAS CHANGED SET VALUE HIGHER THAN PREVIOUS SET VALUE THEN "SET HIGH" LED WILL GLOW OR IF ONE HAS CHANGED SET VALUE LOWER THAN PREVIOUS SET VALUE THEN "SET LOW" LED WILL GLOW AS THE USER COME OUT OF SET MODE . AT POWER ON MODE BOTH THE LEDS WILL BE "OFF".

NOTE :DURING "POWER ON", IF THE USER IS IN "SKIN" MODE THEN ALL SETTINGS WILL BE APPLICABLE TO SKIN MODE & IF USER IS IN "AIR MODE" THEN ALL SETTINGS WILL AUTOMATICALLY APPLICABLE TO AIR MODE.

GLOBLE SETTING MODE:

TO ADJUST PARAMETERS LIKE ALARM HIGH (HIGH TEMPERATURE),ALARM LOW (LOW TEMPERATURE),POWER IN % FOR MANUAL MODE & MUTE TIMER DO THE PROCEDURE SHOWN BELOW,

PUSH "UP" & "DOWN" ARROW KEYS FOR 30 SECONDS, "A1" WITH SOME NUMBER WILL BE DISPLAYED ON DISPLAY-1. THIS IS ALARM LOW SETTING (LOW TEMPERATURE). SET IT BY "UP" OR "DOWN" KEY TO DESIRED VALUE. (FROM 0.0 TO 9.9°C). IF ONE HAS PUT SET POINT AS 33.0°C & "A1" AS 2.0°C THEN THE BUZZER WILL START SOUNDING AS THE SKIN TEMPERATURE GOES BELOW 31.0°C.

PUSH "SET" KEY AGAIN TO GO TO NEXT PARAMETER SET MODE BY SAVING CURRENT / CHANGED VALUE OF "A1". NOW "Ah1" WITH SOME NUMBER WILL BE DISPLAYED ON DISPLAY-1. THIS IS ALARM HIGH SETTING (HIGH TEMPERATURE). SET IT BY "UP" OR "DOWN" KEY TO DESIRED VALUE. (FROM 0.0 TO 9.9°C). IF ONE HAS PUT SET POINT AS 33.0°C & "Ah1" AS 2.0°C THEN THE BUZZER WILL START SOUNDING AS THE SKIN TEMPERATURE GOES ABOVE 35.0°C.

PUSH "SET" KEY AGAIN TO GO TO NEXT PARAMETER SET MODE BY SAVING CURRENT / CHANGED VALUE OF "Ah1". "tir" WILL FLASH WITH PREVIOUS SET NUMBER. THIS IS MUTE TIMER SETTING. SET IT BY "UP" OR "DOWN" KEY TO DESIRED VALUE. (FROM 0 TO 15 MIN). IF IT IS SET TO "00" THEN THE MUTE TIME IS DISABLED. IF ONE HAS SET ANY VALUE OTHER THAN "00" THEN THE BUZZER WILL SOUND AFTER THIS SET TIME BUT IT WILL CHECK FOR ALARM CONDITION FIRST. IF IT IS SET TO "00" THEN "MUTE" LED WILL BE CONTINUOUS "ON" & IF IT IS SET OTHER THAN "00" THEN "MUTE" LED WILL FLASH ON EVERY SECOND WHICH INDICATES THAT THE MUTE TIMER IS RUNNING.

PUSH "SET" KEY AGAIN TO GO TO NEXT PARAMETER SET MODE BY SAVING CURRENT / CHANGED VALUE OF "tir". NOW "erp" WILL FLASH WITH SOME NUMBER ALTERNATELY. THIS IS POWER SETTING IN % FOR MANUAL MODE IF THE SENSOR FAILS (ERR). SET IT BY "UP" OR "DOWN" KEY TO DESIRED VALUE. (FROM 10 TO 99%) FACTORY SET IS 30%. IN THIS MODE THE POWER WILL BE 30% INITIALLY BUT IF ONE HAS CHANGED IT TO OTHER VALUE SAY 60% THEN THE POWER WILL BECOME 60% AS THE SENSOR FAILS. THIS CHANGED POWER WILL REMAIN TILL NOBODY SETS IT AGAIN.

PUSH "SET" KEY AGAIN TO GO TO NEXT PARAMETER SET MODE BY SAVING CURRENT / CHANGED VALUE OF "erp". NOW "Por" WILL FLASH WITH SOME NUMBER ALTERNATELY. THIS IS POWER SETTING IN % FOR MANUAL MODE. SET IT BY "UP" OR "DOWN" KEY TO DESIRED VALUE. (FROM 10 TO 99%). IN MANUAL MODE THE POWER WILL BE 40% INITIALLY BUT IF ONE HAS CHANGED IT TO OTHER VALUE SAY 60% FROM THIS MODE THEN THE POWER WILL BECOME 60% AS THE USER COME OUT OF THIS MODE. THIS CHANGED POWER WILL REMAIN FOR 15 MINS ONLY & AFTER THAT IT WILL BECOME 40% AUTOMATICALLY.

ONE CAN DIRECTLY CHANGE THIS BY PUSHING DECREMENT KEY FOR 30 SECONDS IN NORMAL MODE. ONE CAN SET IT BY UP OR DOWN KEY. PUSH SET TWICE TO GO OUT OF THIS MODE.

NOTE: DO NOT SET "Ser" & "Aer" TO ANY VALUE OTHER THAN ZERO. THIS MODE WILL COME INTO PICTURE IF BOTH THE SENSOR FAILS.

DURING POWER "ON",DISPLAY IS ALWAYS IN °C INDICATION MODE TO TOGGLE BETWEEN °C & °F PUSH °C/°F KEY ONCE. °F LED WILL GLOW TO INDICATE THAT THE DISPLAY IS IN °F MODE. TO COME OUT OF °F MODE PUSH °C/°F KEY AGAIN & THE LED WILL BE OFF.

TO SHIFT TO AIR MODE PUSH "AIR" KEY ONCE. UNIT WILL START WORKING IN AIR MODE & AIR LED WILL GLOW. HERE THE CONTROL ACTION WILL START AS SOON AS USER ENTERS IN THIS MODE. INDICATION IS ALSO GIVEN ON LCD DISPLAY TO RIGHT HAND SIDE OF THE TOP ROW OF LCD DISPLAY.("AIR" WILL BE DISPLAYED). RESPECTIVE % OF POWER WILL ALSO BE DISPLAYED ON RIGHT SIDE CORNER OF SECOND ROW OF LCD DISPLAY. IF THE POWER IS 40% THEN THE HEATER WILL BE ON FOR 40% OF 60 SEC (CYCLE TIME)= 24

SEC. HERE THE % OF POWER CAN BE CHANGED.

TO SHIFT TO SKIN MODE PUSH "SKIN" KEY ONCE. UNIT WILL START WORKING IN SKIN MODE & SKIN LED WILL GLOW. IN THIS MODE THE POWER CONTROL WILL BE AUTOMATIC WITH RESPECT TO THE SET TEMPERATURE. HERE THE CONTROL ACTION WILL START 1.0°C BELOW SET POINT & WITH THE CYCLE TIME (FOR ON/OFF) OF 60 SEC. INDICATION IS ALSO GIVEN ON LCD DISPLAY TO RIGHT HAND SIDE OF THE TOP ROW OF LCD DISPLAY.("SER" WILL BE DISPLAYED). RESPECTIVE % OF POWER WILL ALSO BE DISPLAYED ON RIGHT SIDE CORNER OF SECOND ROW OF LCD DISPLAY. IF THE POWER IS 50% THEN THE HEATER WILL BE ON FOR 50% OF 60 SEC (CYCLE TIME)= 30 SEC.

AT POWER ON "APGAR" TIMER IS ALWAYS "00". TO START IT, PUSH "START" KEY. START LED WILL START BLINKING ON EVERY SECOND WHICH INDICATES THAT "APGAR" TIMER IS RUNNING. THIS WILL GIVE ALARM AFTER 1MIN FIRST, FOR 10 SECS DURATION. AFTER THAT IT WILL GIVE THE ALARM AFTER EVERY 5 MINS FOR THE DURATION OF 10 SECS. FIRST PRIORITY FOR ALARM IS GIVEN TO "APGAR" TIMER. HENCE IF IT IS MUTED EARLIER FOR ANY FAULT CONDITION THEN ALSO IT WILL COME OUT OF MUT MODE IT THE "APGAR" IS GIVING SIGNAL FOR ALARM. AFTER 15 MINS "APGAR" TIMER WILL BECOME "00" & TO START IT AGAIN, ONE HAS TO PUSH START KEY. THE SAME THING WILL HAPPEN AGAIN.

FAULT MESSAGES & INDICATIONS :-"SKIN HIGH" & "SKIN LOW", "AIR HIGH" & "AIR LOW" MESSAGES WILL BE DISPLAYED ON FIRST ROW OF LCD DISPLAY. ALSO THE TEMPERATURE HIGH & LOW LED WILL GLOW AS PER THE SITUATION BY GIVING AUDIO ALARM WHICH CAN BE MUTED BY "MUTE" KEY. MUTE KEY IS TO MUTE THE ALARM. SKIN PROBE FAIL INDICATION IS ALSO GIVEN ON FIRST ROW LCD DISPLAY. PROBE FAIL LED WILL GLOW & "Err" WILL BE DISPLAYED ON DISPLAY-1 / DISPLAY-2."Err" WILL BE DISPLAYED IF THE PROBE IS OPEN OR IF THE TEMPERATURE GOES ABOVE 100°C BY TRIGGERING TEMPERATURE HIGH LED OR BELOW 0°C BY TRIGGERING TEMPERATURE LOW LED.

ALARM CONDITIONS:

AUDIO ALARM WILL SOUND AFTER THE COMPLITION OF MUTE TIME BUT IT WILL CHECK FOR THE ALARM CONDITION FIRST. IF NO ERROR MESSAGE ON DISPLAY & IF THERE IS NO FAULT IN THE UNIT THEN THE ALARM WILL BE OFF OR IT WILL COME OUT OF MUTE MODE IF IT IS MUTED FOR THE PREVIOUS ERROR / FAULT CONDITION.

POWER FAIL ALARM & INDICATION IS ALSO GIVEN. THERE IS NO MUTE GIVEN FOR POWER FAIL MODE BUT IT WILL BE OFF AFTER 60 SECONDS. BATTERY BACK-UP IS GIVEN WITH TRICKLE CHARGING. "9V" RECHARGABLE BATTERY IS PREFERABLE.

MASTER RELAY WILL CUT-OFF WHEN SKIN TEMPERATURE GOES ABOVE 38 DEG AIR GOES ABOVE 38 DEG. CELSIUS IN SKIN MODE. POWER WILL BE ZERO AT 37°C IN MANUAL MODE. ALSO IT WILL BE ZERO IF THE SKIN TEMPERATURE REACHES TO SET TEMPERATURE IN SERVO MODE. IT GOES TO MAN MODE FROM SKIN MODE / AIR MODE AUTOMATICALLY IF THE SENSOR FAILS IN NORMAL MODE.